

# *Accident Prevention Through the use of A Vehicle Tracking System*

Shilpa Guleria, Neha Goyal  
Department of Computer Science  
BN College of Engineering and Technology,  
Lucknow, India

**Abstract—** Traffic accidents are a major cause of mortality in modern societies, and the delay in calling for rescue services can exacerbate the problem. To address this issue, researchers are exploring the use of embedded systems, GPS, and mobile communications to develop in-vehicle automatic accident and theft detection and reporting systems. These systems use sensors in the vehicle to detect accidents or thefts and report the location to emergency services. An efficient system has been proposed that automatically notifies the emergency and police services in case of an accident or theft and guides them to the spot. The system uses a crash sensor to detect an accident and a Datatag Car System to detect theft. It obtains the location of the vehicle using GPS and sends an SMS message via a GSM/GPRS system. The GPS continuously takes input data from the satellite and stores the latitude and longitude values in a microcontroller's buffer. The system sends a message to the predefined device once it detects an accident or theft.

**Keywords—** Vehicle Tracking, Accident Warning, GPS, GSM/GPRS

## **1. Introduction:**

A vehicle tracking system refers to a comprehensive security and fleet management solution that enables the location of a vehicle to be determined using various methods, including GPS and other navigation systems that utilize satellites and ground stations. Other automatic vehicle location methods may also be used occasionally. Modern vehicle tracking systems rely on GPS technology to track and locate cars anywhere in the world. The installed system provides location data and the ability to store and download the data to a computer for further analysis. Automakers consider this device a crucial resource for tracking their vehicles, preventing theft, and recovering stolen cars. The collected data can be accessed online, viewed using software, or displayed on electronic maps after receiving the position coordinate via SMS. The high demand for cars has, however, also increased traffic congestion and car accidents. The people's lives are in terrible risk. This is because our country lacks top emergency facilities. An automatic car accident alert system is presented in this project. This program, which can detect accidents far more quickly and transmits vital information, such as the location, time, and angle at which an accident happened, to a chosen contact (such as the next of kin and the emergency dispatch center) in a matter of seconds. An automobile crash occurred. This alert message is quickly transmitted to the main alarm center, allowing the emergency

dispatch server to immediately alert the emergency services, potentially saving many lives. An alert message is automatically transmitted to the alarm center in the event of an accident. The GSM is what sends the communication. Using the GPS module, the GPS module locates the accident's location. A vibration sensor can be used to precisely identify an accident. This method offers the best possible option for difficult cases related to auto accidents. The "Vehicle Tracking and Accident Warning System Using GPS and GSM Technology" project was created to address the requirements of today's fleet management firms. It is a very practical and adaptable tool that you can use. An electronic device that is installed in a car as part of a vehicle tracking and emergency alert system allows its owner or another party to track the whereabouts of the vehicle. The Global Positioning System, sometimes known as GPS, is used by the majority of contemporary car tracking systems to determine the precise location of the vehicle. The location of the vehicle is transmitted to a distant user using a combination of communication tools, including a mobile phone (GSM) and a satellite transmitter. Software on a computer can be used to view vehicle information. Vehicle tracking systems are often used by fleet managers for fleet management tasks like routing, dispatching, and vehicle information. and safety. Monitoring driving behavior is another use, for example, by a parent of a young driver or an employer of an employee. Commercial vehicles frequently use vehicle tracking systems as a tracking and anti-theft tool. The tracking system's signal may easily be followed by the police to find the stolen car. A vehicle tracking system can function as an addition to or a replacement for a conventional automobile alarm when utilized as a security system. As a result of the greatly decreased danger of losing the vehicle, the existence of a vehicle tracking system can lower insurance rates. Vehicle Other applications for tracking include asset monitoring scenarios, where businesses who need to track a valuable asset for insurance or other reasons may now map the asset's location in real time and correctly follow movement and operational status. The situation of sales professionals is, nevertheless, readily available in real-time locations in mobile field sales. For instance, they may locate themselves, customers, and potential customers in strange locales, acquire driving instructions, and include last-minute appointments in travel schedules. Benefits include higher output, shorter travel distances, and more contact with customers and potential customers.

## **2. Statement of Problem**

Available online at: [www.ijrdase.com](http://www.ijrdase.com) Volume 24, Issue 1, 2024

All Rights Reserved © 2024 IJRDAE

The issue of rising crime rates is a global challenge that requires prompt actions from both developing and developed nations. In Nigeria, for instance, car theft cases have been on the rise with an average of 2,000 reported cases yearly as of 2011 [Nairaland.com]. Stolen cars are often sold, rebuilt, or destroyed if the resale value is low, making it difficult to track and recover them. To tackle this problem, this paper provides suggestions on how to design and implement an anti-burglary system for cars to enhance their protection and security. Additionally, poor driving habits, coupled with the poor state of roads and increased street activity, have led to a surge in vehicle accidents and street mishaps, accounting for 35% of fatalities in Nigeria in 2016. The primary aim of this initiative is to improve the survival chances of victims involved in such incidents.

#### A. Motivation

The disturbing pace of vehicle robbery and street mishaps was the significant inspiration for this task. I Having once survived a street accident, I had been motivated to find a solution. I am confident that this methodology, if implemented properly, will help increase the likelihood of recovering stolen automobiles, hence raising vehicle security. Additionally, it will increase the likelihood of accident fatalities through the accident-ready system.

#### B. Project point and goals

The goal of this project is to plan and develop a framework for vehicles to follow and be prepared for accidents using GPS and GSM innovation..

#### C. Goals of this task are:

- i. To examine and research the GPS module's primary function.
- ii. To design the GPS/GSM and Pushbutton with the framework in mind.
- iii. To ensure that the plan is flawless through breadboard design and role-playing.
- iv. To apply the planned framework to a model of the relevant equipment.
- v. To analyze the effectiveness of the developed framework.

#### D. Scope of Study

Programming and equipment improvements were the major additions considered in this project. The equipment enhancement is characterized by the power supply unit (AC to DC) and wiring of the modules with the microcontroller. The product meeting also includes writing source code for the microcontroller and using Google's programming interface to view one's location on a map of Google. The VTAA (Vehicle Following and Mishap Alert) framework's planning and development are properly covered by this meetings.

### 3. Literature Review

The GPS Framework, which was initially constructed and operated with 24 satellites (21 necessary and 3 optional), was created and approved by the American Branch of Defense

(DOD). Around 30 operational satellites circle the earth at a distance of 202 km at the moment. GPS satellites emit signals that make a certain area possible if a GPS collector is placed on the surface of the earth, in the environment of the earth, or in a low-lying location. GPS is used for on-land, at sea, and in flight navigation. The use of it in land evaluations and other circumstances when the certainty of a particular position is needed. Anyone with a GP (wikipedia, 2016) collector may use the GPS symbol without paying a fee (U.S. Division of State, 2013).

#### A. GSM TECHNOLOGY

The American Branch of Defense (DOD) created and approved the GPS Framework, which was initially established and operated with 24 satellites (21 needed and 3 optional). Currently, 30 or so active satellites orbit the earth at a distance of 20200 km. If a GPS collector is located on the surface of the earth, in the environment of the earth, or in a low circle, GPS satellites transmit signals that enable the precise region of the GPS collector. GPS is used for navigation during flight, at sea, and on the ground. Additionally, it is used in land reviews and other situations when the assurance of a particular position is needed. Anyone with a GP (wikipedia, 2016) collector may use the GPS symbol without paying a fee (U.S. Division of State, 2013).

In 1973, the decision was made to support a satellite route framework in light of the Travel, TIMATION, and 621B frameworks of the U.S. Naval force and aviation-based armed forces. First collector tests are conducted after four years, even before the primary satellites are positioned in the circle. On the surface of the world, transmitters are introduced and called Pseudolites (false lites) satellites). 11 Block I satellites are sent into orbit in total by 1985. The decision to expand the GPS framework has been made. The assets are drastically reduced right away, and the software is rewritten. 18 satellites should be worked on first. In 1988, the number of satellites was once more increased to 24, as only 18 satellites were useful.

According to Ramya et al. (2012), by replacing the existing modules, this framework provided vehicle lodge welfare and security in light of the implanted framework. This method monitors the level of dangerous gases, such as CO, LPG, and alcohol, inside the vehicle and provides timely information as a warning during dangerous circumstances. The approved person is sent away over GSM via the SMS. In this approach, the IR Sensor is employed to differentiate between the static deterrent ahead of the vehicle and the vehicle halted in the case that any obstruction is detected. This is keeping away from mishaps because of crash of vehicles with any static impediments.

For applications relating to the wellbeing of vehicles, Tune et al. (2005) planned and used a continuous visual global positioning system. In this work, a sophisticated element-based vehicle-following algorithm is built, which naturally identifies and follows a few moving objects in front of the following vehicle, such as motorcycles and cars. Together with the concept of the enemy as the main point of development and perspective analysis, the created framework

can separate moving objects from moving foundation and propose a crash. continual indication of caution. The suggested calculation makes use of a CMOS image sensor and an embedded NMOS CPU architecture. The independently constructed global positioning system passed tests on actual city streets. The findings revealed information on crashes in urban areas with speeds about 60 km/h, both during the day and at night.

**4. Methodology**

In the proposed work, a sophisticated method for vehicle following and an accident warning system were employed to track the getaway car using GPS and GSM technology. This system switches to rest mode while the vehicle operated by the owner or authorized person still operates in dynamic mode, the mode of operation being changed in person or remotely. If an accident occurs, the air pack's press button connected to it recognizes a sign and sends an SMS to the microcontroller. The authority notifies the owner of the vehicle or any designated party of the accident with the vehicle.

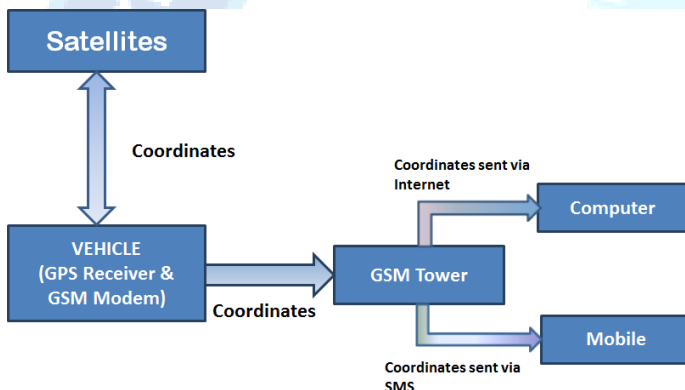
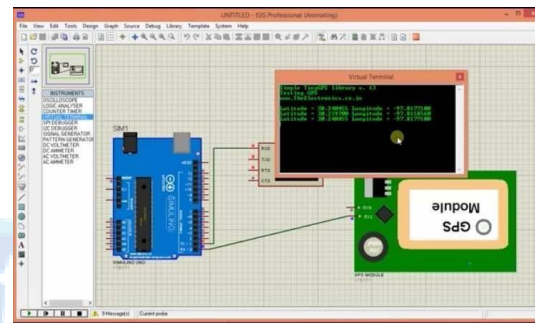

**Fig.3.1:** Block Diagram of Vehicle Tracking System

**A. MAJOR COMPONENTS USED:**

- ATMEGA 8 AVR
- Parallax GPS Receiver Module
- SIM 800
- PUSH BUTTON
- POWER SUPPLY

In the proposed work, a sophisticated method for vehicle following and an accident warning system were employed to track the getaway car using GPS and GSM technology. This system switches to rest mode while the vehicle operated by the owner or authorized person still operates in dynamic mode, the mode of operation being changed in person or remotely. If an accident occurs, the air pack's press button connected to it recognizes a sign and sends an SMS to the microcontroller. The authority notifies the owner of the vehicle or any designated party of the accident with the vehicle.



**Fig.3.2:** Simulation of a VTAA system using Proteus software

**B. MICROCONTROLLER**

The Atmel®AVR® ATmega8 microcontroller used in this study is a low-power CMOS 8-bit microcontroller based on AVR RISC engineering. The ATmega8 achieves throughputs approaching 1MIPS per MHz by following strict rules in a single clock cycle, enabling the system designed to increase power efficiency rather than processing performance.

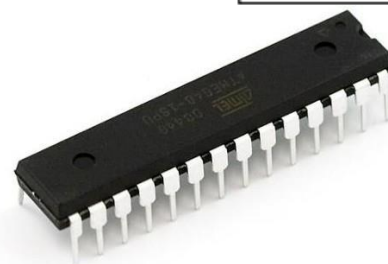
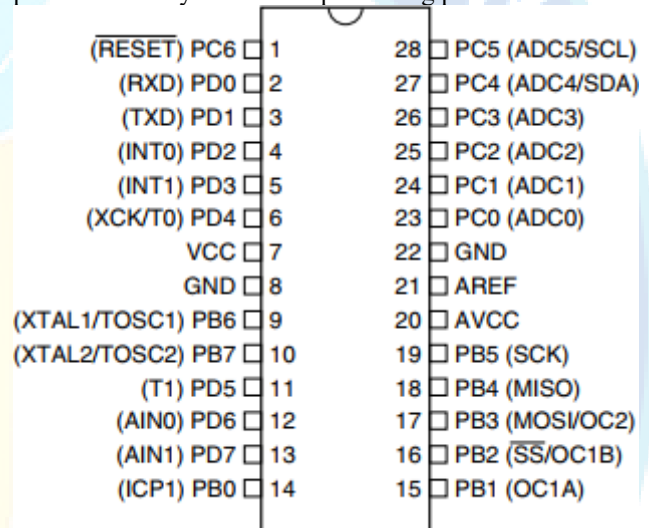

**Fig. 3.2 pin diagram of microcontroller ATMEGA 8 (Atmel, 2013)**

**C. ATMEGA 8 Pin Descriptions VCC: Digital supply voltage.**

GND: Ground.

Port B (PB7..PB0) XTAL1/XTAL2/TOSC1/ TOSC2: 8-bit bidirectional I/O port Port B has inner draw up resistors that are specifically chosen for each piece. Even driving qualities with large sink and source capacities are present in the Port B yield supports. Port B sticks that are remotely pulled low will source current if the draw up resistors are activated, according to information sources. Regardless of whether the clock is



operating or not, the Port B pins are tri-expressed when a reset state becomes dynamic. Port C (PC5...PC0): Seven-piece, bidirectional Port C has internal draw-up resistors that are specifically chosen for each component. The Port C result backs even driving characteristics with both high source and sink capacity. Port C pins that are remotely pulled low will source current if the draw up resistors are started, according to this information. Whether or not the clock is running, the Port C pins are tri-expressed when a reset condition becomes dynamic.

In the unlikely event that the RSTDISBL Wire is modified, PC6 is used as an I/O pin. Keep in mind that PC6's electrical characteristics differ from those of the various Port C pins. PC6 is used as a Reset input in case the RSTDISBL Circuit is changed. Regardless of whether the clock is not running, a low level on this pin for a longer period of time than the base heartbeat length will result in a Reset. Port D (PD7...PD0) is an 8-cycle bi-directional I/O port with internal pull-up resistors that are specifically chosen for each component. The result cradles for Port D even have driving characteristics with high capacity sources and sinks. If the draw up resistors are started, remotely pulled low Port D pins will source current as information sources. Whether or whether the clock is running, the Port D pins are tri-expressed when a reset state becomes dynamic.

II. Testing, ANalysis of Result and Discussion

A. Hardware Assembling and Testing:

Making a transition board design for the circuit diagram was the first action conducted. Following that, the accompanying advancements were then made.

1. Put every component on the transition board together according to the circuit diagram, connect the GSM modem's TX and RX pins to pins 13 and 14 of the MAX 232, and insert a sizable SIM into the GSM modem.
2. Attach the GPS module as shown on the circuit diagram.
3. The project was successfully carried out and tried.
4. For owners of vehicles, this structure is incredibly beneficial and secure.

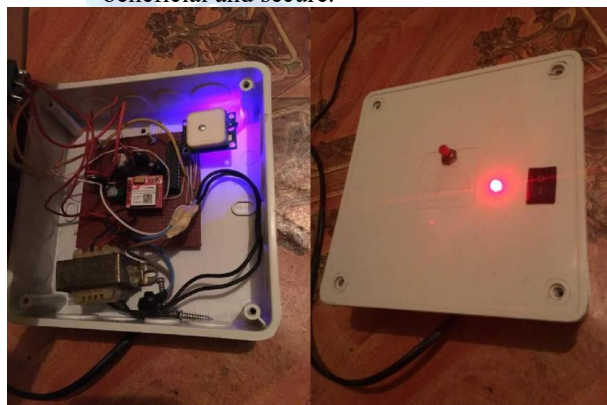

Fig 4.1: view of project during testing and evaluation

5. Results

I have integrated a component that will send SMS to the client upon request to enable checking the location of the vehicle in

the event of an accident or vehicle theft. The value of the vehicle's latitude and longitude will be put into SMS. The SMS also includes a link that enables the customer to view the location using Google Maps.

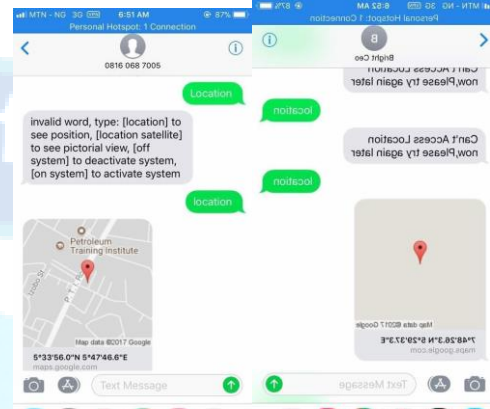

Fig 4.2: view of communication between user and VTAA system via text message

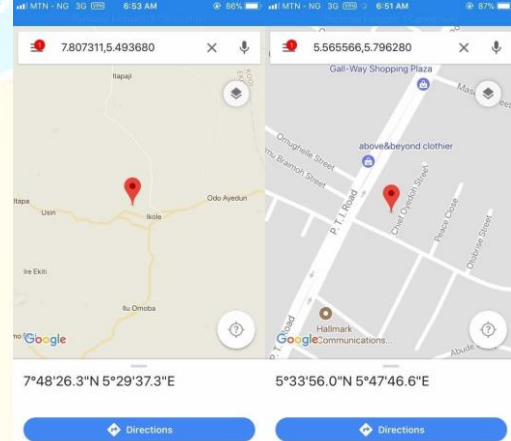

Fig 4.3: View of location on website through Google map

B. PERFORMANCE EVALUATION

I evaluated the entire plan of action while keeping an eye on the delayed evaluation. It is how long I saw the in-vehicle device taking to answer or send an SMS, keeping the end user in mind. We used the SIM cards 655556UU of four different directors to create this impression of the delay evaluation. The deferral for each set of linked SIM cards was then recorded. We have used SIM cards from MTN, 9MOBILE, Glo, and Airtel, which are four different providers. It is done to keep track of different data game strategies, and regular time is meant to focus on the concede test. The table below displays the outcomes.



I tested the complete course of action while observing the delayed assessment. With the end user in mind, it is how long I saw the in-vehicle device taking to respond or send an SMS. To construct this impression of the delay assessment, we used the SIM cards 6555556UU of four unique directors. We then recorded the deferral for each pair of linked SIM cards. The four distinct head SIM cards we have used are MTN, 9MOBILE, Glo, and Airtel.

One of the causes of this delay is that this GSM-based innovation's network dependence on the GSM expert co-op occurs when the vehicle travels through certain regions with poor organization inclusion. According to the analysis done above, each arrangement of information from different administrators has a delay of around 1.5 to 2 minutes, which seems less significant. seconds). Accordingly, MTN network specialist co-op was used in the project's sending and receiving terminals. For instance, correspondence in the form of a Short Message Service (SMS) is made between two MTN specialist organizations, one in the Client terminal (GSM framework) and the other in the device (VTAA framework).

**6. Conclusions**

Vehicle GPS devices have a number of benefits and enhance executives. We can accomplish more in the time we have available if we have better scheduling or course planning. When a personal or professional event occurs, vehicle following enhances safety and security, communication, execution monitoring, and effectiveness. As a result, throughout the course of the upcoming year, assumptions will substantially shift in our day-to-day lives. The main goal of

the accident-ready framework project is to reduce the likelihood that someone would die in an accident that is out of our control. When an accident is suspected, paramedics are dispatched to the scene to increase the chances of survival. Accidents that occur during odd hours will benefit far more from this invention. in areas that are desolate. In the future, this vehicle-following and accident-prepared component will be considerably more common in daily life. In my concept, I've created a precise, adaptive architecture for global vehicle placement. After creating the GSM modem, I experimented with and used the GPS system to track the location of the vehicle online and by SMS. display a Google Map of the situation I've utilized the Google map programming interface. The microcontroller is the system's brain because the GSM modem is constrained by AT directives that allow information transmission via the GSM network and the GPS gives location information. Google Map displays the area whenever the GPS receives new information, which causes the data set to be refreshed The system provides accurate information continuously, enabling the client to track the car and enabling an early recovery in the event that the vehicle is stolen. My understanding of GPS has greatly increased thanks to this proposal, which has also helped me improve my programming skills.

**7. Limitations**

While this state-of-the-art technology-based global positioning system can benefit clients, organizations, or any association, there are some limitations to using this vehicle GPS beacons.

Frequently GPS finds opportunity to interface with the organization because of unfortunate atmospheric conditions. For the GPS to work appropriately, it necessities to have an unmistakable perspective on the sky. That is all there is to it is probably not going to work indoor or may try and have issue outside where it has no make way of sending to and getting signal from satellites. Accordingly, because of obstructions like tall structures or such infrastructure which block view of the sky, often causes multipath error to the getting sign of the GPS beneficiary. Accordingly, area appears to seem to bounce starting with one spot then onto the next prompting off base outcomes. Consequently wrong upsides of scope and longitude are shipped off the server, for showing in the Google map on mistake being instated.

**References:**

Albert Alexe, R., Ezhilarasie. (2011). *Cloud Computing Based Vehicle Tracking Information System Sysytem*.  
 Alex P., Kiran, S., Piraji, D., Imran. (2011). *Cloud Computing Based Vehicle Tracking Information Systems. Cloud Computing Based Vehicle Tracking Information Systems*.  
 Al-Hindawi, A., M. (2012). *Experimentally Evaluation of GPS/GSM Based System Design. Electronic Systems, Volume 2*.  
 Asaad M., J., Al-Hindawi, Ibraheem Talib. (2012). *Experimentally Evaluation of GPS/GSM Based System Design. Electronic Systems*.



- Ashutosh Upadhaya. (2014). *Tracking System Using GSM, GPS & Arm7*. Bombe. Atmel. (2013). Datasheet. 1-331.
- Benjamin B., K. (2013). A Real-Time Computer Vision System for Vehicle Tracking and Traffic Surveillance, Transportation. *Transportation*.
- Chen Peijiang, Jiang Xuehua. (2008). *Design And Implementation of Remote Motoring System Based on GSM*.
- Coifman, B. (2013). *A Real-Time Computer Vision System for Vehicle Tracking and Traffic Surveillance*.
- Global Sytem For Mobile Communication. (2016). <https://en.wikipedia.org/wiki/GSM#history>.
- Henster D. R. (2012). Embedded Smart Car Security System on Face Detection. *Special Issue of Ijct*.
- Kai-Tai Song. (2005). Front Vehicle Tracking using Scene Analysisl. *Proceedings of the IEEE International Conference on Mechatronics & Automation*.
- Khalifa A. Salim P., Kiran, S., Piraji, D., Imran. (2013). Web Based Vehicle Tracking System. *ISSN: 2231-0711 443iv*. (Pp. Issue 12, 443-448). *Ijcsset*.