

# Advanced suspension with Added Fuzzy rule in Hybrid of Sliding mode control mechanism for reducing vibrations in vehicles

Avinash Sharma  
Mechanical Engineering,  
Amity University, Lucknow, India  
avinashsharma7799@gmail.com

Pravin Kumar Singh  
Mechanical Engineering,  
Amity University, Lucknow, India  
pk Singh@lko.amity.edu

**Abstract-**The vehicle suspension supports and isolates the vehicle body and payload from road vibrations because of surface roughness by maintaining a governable damping traction force between tires and paved surface. In trendy luxury vehicles semi active suspension are providing both reliability and accuracy that has increased the traveller ride comfort with less power demand. In this paper we have projected the design of a hybrid system having a mix of skyhook theory with fuzzy logic control and applied on a semi-active vehicle suspension for its ride comfort sweetening. A 2 degree of freedom dynamic model is simulated victimisation Matlab/Simulink for a vehicle equipped with semi-active suspension with targeted on the passenger's ride comfort performance.

**Keywords-**Fuzzy inference system, vibration control, sliding surface, error control

## 1. Introduction:

The quarter-vehicle model was initially developed to explore active suspension capabilities and gave birth to the concepts of skyhook damping and fast load leveling, which are now being developed toward actual large-scale production applications. The ideal Skyhook control strategy was introduced in 1974 by Karnopp et al, which is known as one of the most effective in terms of the simplicity of the control algorithm. The basic idea is to link the vehicle body sprung mass to the stationary sky by a controllable 'skyhook' damper, which could generate the controllable force of skyhook and reduce the vertical vibrations by the road disturbance of all kinds. Their original work uses only one inertia damper between the sprung mass and the inertia frame. The skyhook control is applicable for both a semi-active system as well as an active system. In practical, the skyhook control law was designed to modulate the damping force by a passive device to approximate the force that would be generated by a damper fixed to an inertial reference as the 'sky'.

The skyhook control can reduce the resonant peak of the sprung mass quite significantly and thus can achieve a good ride quality. By borrowing this idea to reduce the sliding chattering phenomenon, a soft switching control law is introduced for the major sliding surface switching, which is to achieve good switch quality for the Skyhook SMC.

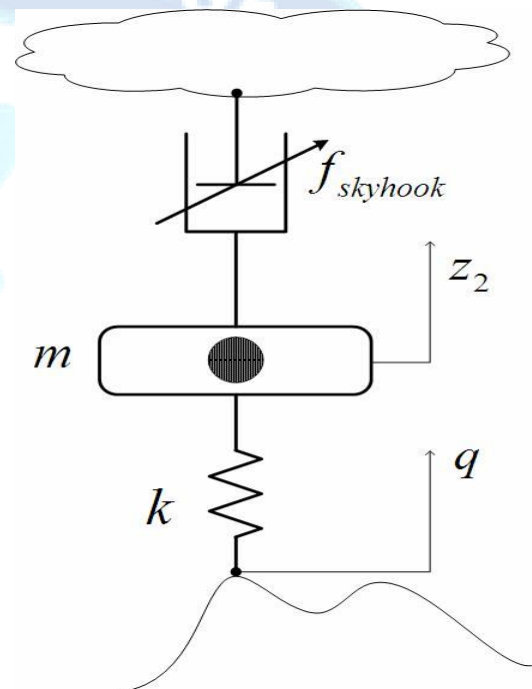


Fig 1: Ideal Skyhook control scheme.

## 1.1 Sliding Mode Control:

Variable structure control (VSC) with sliding mode control was introduced in the early 1950s by Emelyanov and was published in 1960s, further work was developed by several researchers. Sliding mode control (SMC) has been recognized as a robust and efficient control method for complex high order nonlinear dynamical system. The major advantage of sliding mode control is the low sensitivity to a system's parameter changing under various uncertainty conditions, and it can decouple system motion into independent partial components of lower dimension, which reduces the complexity of the system control and feedback design. A major drawback of traditional SMC is chattering, which is generally disadvantageous within control system.

In recent years, a lot of literature has been generated in the area of SMC and has covered the improvement for traditional SMC, they harnessed to achieve better performance and reduce the chattering problem.

In this work our objective is to the design of a hybrid control system, combination of skyhook surface sliding mode control method and fuzzy logic control method and will be applied on a semi-active vehicle suspension system for its ride comfort enhancement. A two degree of freedom

mathematic model of a vehicle semi-active suspension system is given which focused on the passenger's ride comfort performance. We will design it on MATLAB/SIMULINK software.

## 2. Related Work:

**M. Kondalu et. al. (2012) [5]**, worked on Fuzzy logic based control systems that provide a simple and efficient method to control highly complex and imprecise systems. However, the lack of a simple hardware design that is capable of modifying the fuzzy controller's parameters to adapt for any changes in the operation environment, or behaviour of the plant system limits the applicability of fuzzy based control systems in the automotive and industrial environments. Adaptive control is the control method used by a controller which must adapt to a controlled system with parameters which vary or are initially uncertain. Despite the lack of a formal definition, an adaptive controller has a distinct architecture, consisting of two loops control loop and a parameter adjustment loop.

**Rajeswari Kothandaraman et. al (2012) [4]**, proposed a Particle Swarm Optimization (PSO) technique that is applied to tune the Adaptive Neuro Fuzzy Controller (ANFIS) for vehicle suspension system. LQR controller is used to obtain the training data set for the vehicle suspension system. Subtractive clustering technique is used to formulate ANFIS which approximates the actuator output force as a function of system states. PSO algorithm search for optimal radii for subtractive clustering based ANFIS. Training is done off line and the cost function is based on the minimization of the error between actual and approximated output. Simulation results show that the PSO-ANFIS based vehicle suspension system exhibits an improved ride comfort and good road holding ability.

**Yanqing LIU et. al. [3]**, worked on a semi-active systems with variable stiffness and damping have demonstrated excellent performance. However, conventional devices for controlling variable stiffness are complicated and difficult to implement in most applications. To address this issue, a new configuration using two controllable dampers and two constant springs is proposed. This work presents theoretical and experimental analyses of the proposed system. A Voigt element and a spring in series are used to control the system stiffness. The Voigt element is comprised of a controllable damper and a constant spring. The equivalent stiffness of the whole system is changed by controlling the damper in the Voigt element, and the second damper which is parallel with the other elements provides variable damping for the system. The proposed system is experimentally implemented using two magneto rheological fluid dampers for the controllable dampers. Eight different control schemes involving soft suspension, stiff suspensions with low and high damping, damping on-off (soft and stiff), stiffness on-off (low and high), and damping and stiffness on-off control are explored. The time and frequency responses of the system to sinusoidal, impulse and random excitations show that variable stiffness and damping control can be realized by the proposed system. The system with damping and stiffness on-off control provides excellent vibration isolation for a broad range of excitations.

**J.J. Slotine et. al, (1982) [2]**, developed a methodology of feedback control to achieve accurate tracking in a class of non-linear, time-varying systems in the presence of disturbances and parameter variations. The methodology uses in its idealized form piecewise continuous feedback control, resulting in the state trajectory 'sliding' along a time-varying sliding surface in the state space. This idealized control law achieves perfect tracking; however, non-idealities in its implementation result in the generation of an undesirable high frequency component in the state trajectory. To rectify this, we show how continuous control laws may be used to approximate the discontinuous control law to obtain robust tracking to within a prescribed accuracy and decrease the extent of high frequency signal. The method is applied to the control of a two-link manipulator handling variable loads in a flexible manufacturing system environment.

A tutorial account of variable structure control with sliding mode is presented by **John Y. Hung et al., (1993) [1]**. The purpose is to introduce in a concise manner the fundamental theory, main results, and practical applications of this powerful control system design approach. This approach is particularly attractive for the control of nonlinear systems. Prominent characteristics such as invariance, robustness, order reduction, and control chattering are discussed in detail. Methods for coping with chattering are presented. Both linear and nonlinear systems are considered. Future research areas are suggested and an extensive list of references is included.

## 3. Methodology:

Fuzzy logic control is a practical alternative for a variety of challenging control applications, because it provides a convenient method for constructing nonlinear controllers via the use of heuristic information. The fuzzy logic control's rule-base comes from an operator's experience that has acted as a human in the loop controller. It actually provides a human experience based representing and implementing the ideas that human has about how to achieve high performance control.

The structure of the FLC for the 2-DOF SA suspension system is shown in Fig. 2, the 'If Then' rule-base is then applied to describe the experts' knowledge. Fig. 2 is the 2-in-1-out FLC rule-base cloud which can drive the FLC inference mechanism. The FLC rule-base is characterized by a set of linguistic description rules based on conceptual expertise which arises from typical human situational experience. The 2-in-1-out FLC rule-base for the ride comfort of the 2-DOF SA suspension system is given, which came from previous experience gained for the semi-active damping force control during body acceleration changes for ride comfort. Briefly, the main linguistic control rules are: 1) when the body acceleration increases, the SA damping force increases; 2) Conversely, when the body acceleration decreases, the SA damping force decreases.

Figure 1 also shows the rule-base 3D cloud map plot, which defines the relationship between 2 inputs of the error (E) and the change in error (EC) with 1 output of the semi-active control force (U). The full 2-in-1-out FLC rule-base is given in Table 1, which can map the FLC rule-base based on the

information of semi-active suspension body acceleration to the output control force.

Fuzzification is the process of decomposing the system inputs into the fuzzy sets, that is, it is to map variables from practical space to fuzzy space. The process of fuzzification allows the system inputs and outputs to be expressed in linguistic terms so that rules can be applied in a simple manner to express a complex system. In the FLC for 2-DOF SA suspension system, there are 7 elements in the fuzzy sets for 2 inputs of Error(E) and Error in Change(EC) and 1 output of FL are: < NL, NM, NS, ZE, PS, PM, PL > for the Fuzzy Inference System (FIS) . De-fuzzification is the opposite process of fuzzification, it is to map variables from fuzzy space to practical space.

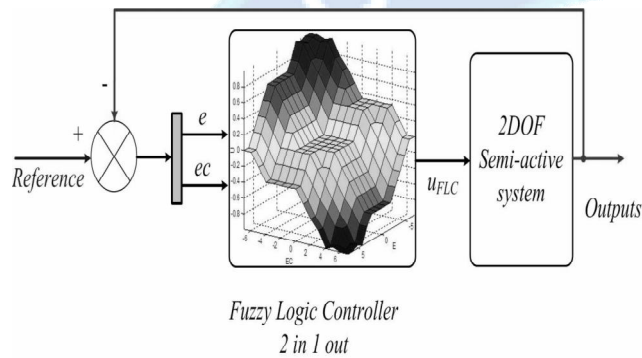


Fig 2: 2-in-1-out fuzzy logic control workflow diagram.

Basically, a membership function (MF) is a generalization of the indicator function in classical sets, which defines how each point in the input space is mapped to a membership value between 0 and 1. The MF for the 2-DOF SA suspension system is the triangular shaped membership function, the MF for E is shown in Figure 3, the MF for EC and U are also triangular-shaped membership function with same elements range. The inputs of E and EC are interpreted from this fuzzy set, and the degree of membership is interpreted.

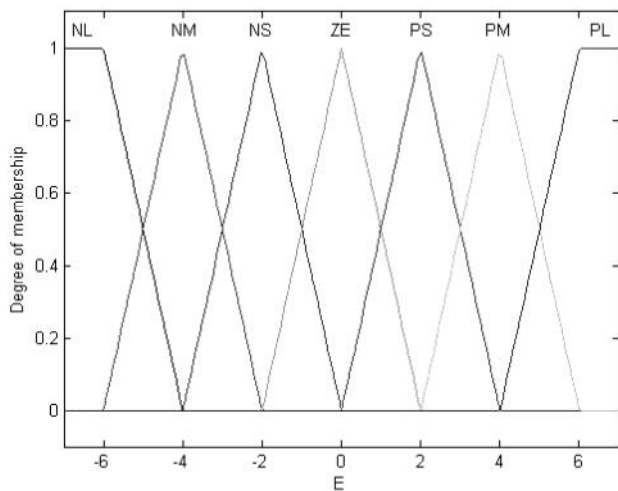


Fig 3. Triangular-shaped membership function for FLC controller.

### 3.1 Model Of Force Balance Equation For Un-Sprung Mass:

In this model we have connected these road disturbance signals to force balance equation (1) of un-sprung mass ( $m_1$ ). This equation uses parameters given in table: (1). This model represents force equation for un-sprung mass which is shown in Fig 4

This figure consists of data input blocks representing the simulation parameters used in the force equation of 2-DOF SAS system.

The unmasked diagram of data input block is shown in fig 5. It consists of & constant input blocks in which we have defined the parametric values of  $m_1, m_2, k_1, k_2, c_0, f_r, g$ . All the constant inputs pass through a multiple block of size  $7 \times 1$  as the mux output is mentioned as simulation parameter. The multiplexed output is then de-multiplexed using a de-multiplexer and we are considering mass  $m_1$  along with displacement  $z_1$  and  $z_2$  obtained from the output of the product block. In this model summer block is producing  $m_1 z_1''$  as the force produced on acting on un-sprung mass  $m_1$  where  $z_1''$  is the acceleration of  $m_1$  due to body inertia & load disturbance. This force is summation of  $k_1(z_1 - q), k_2(z_1 - z_2), c_0(z_1' - z_2'), -m_1 g$  and  $f_r (=c_2(z_2' - z_1'))$  and the output of sum up is multiplied by  $1/m_1$  using product block. In this way the product block is providing  $z_1''$

Table 1: 2-DOF SA suspension parameters

$m_1$	Un-sprung mass, kg	36
$m_2$	Sprung mass	240
$c_2$	Suspension damping coefficient, Ns/m	1400
$k_1$	Tire stiffness coefficient, N/m	160000
$k_2$	Suspension stiffness coefficient, N/m	16000
$G$	Gravity acceleration, $m/s^2$	9.81
$K_e$	FLC scaling gain for e	-1
$K_{ec}$	FLC scaling gain for ec	-10
$K_u$	FLC scaling gains for u	21
$C_0$	SkyhookSMC damping coefficient	-5000
$\Delta$	Thickness of the sliding surface	28.1569
$\Lambda$	Slope of the sliding surface	10.6341
$N_0$	Reference space frequency, $m^{-1}$	0.1
$P(no)$	Road roughness coefficient, $m^3/cycle$	$250 \times 10^{-6}$
$V_0$	Velocity, km/h	72

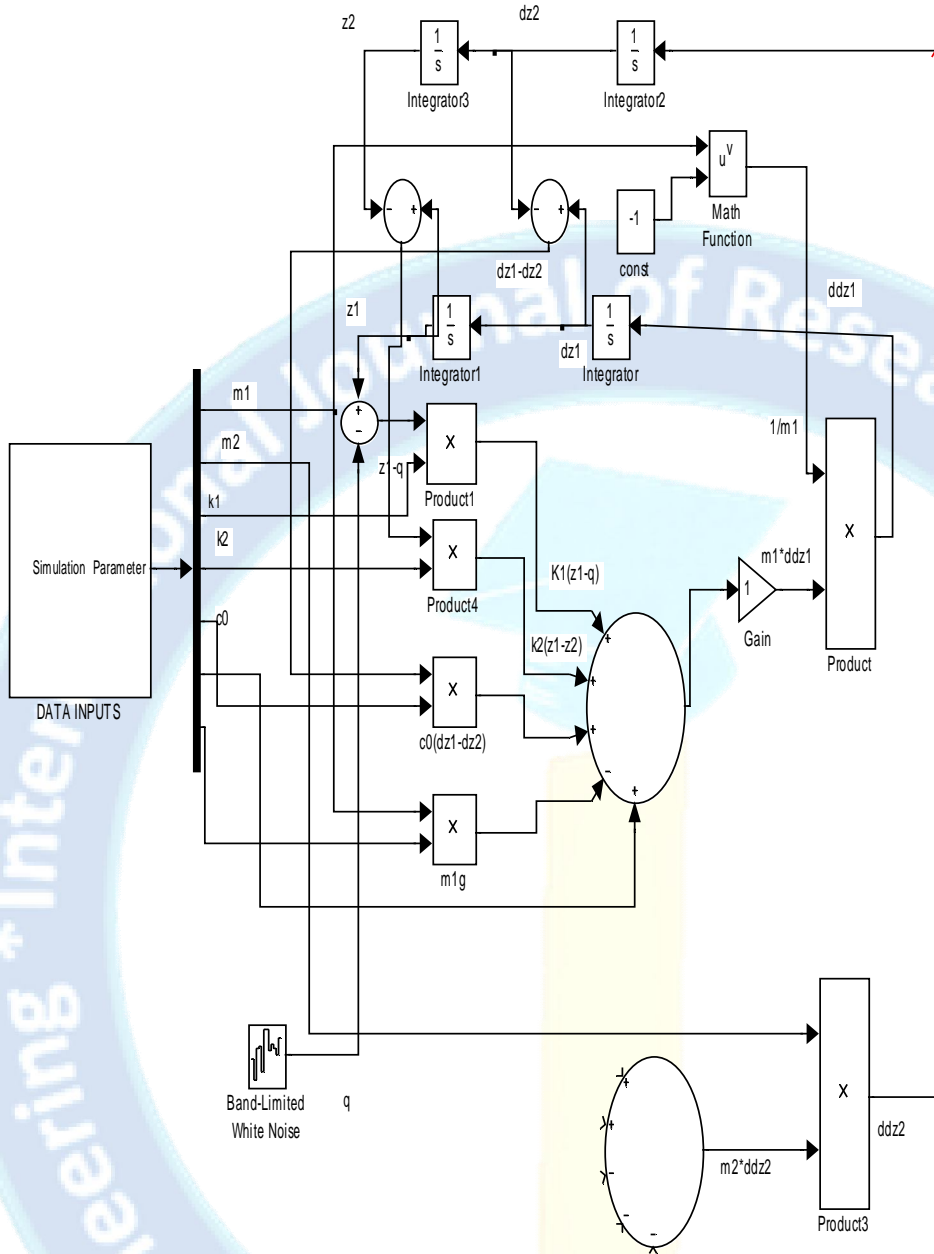


Fig 5 Model of Force Balance Equation for Un-sprung Mass

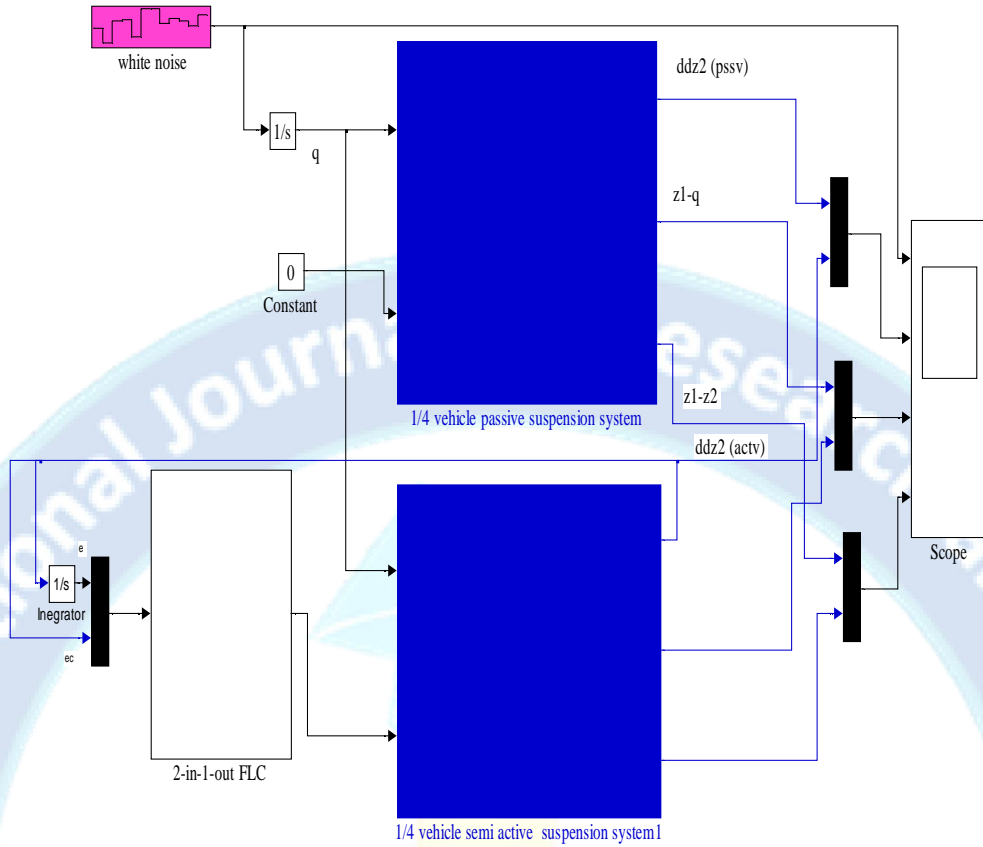


Fig 6 (a): Simulink Model of Fuzzy control Suspension system

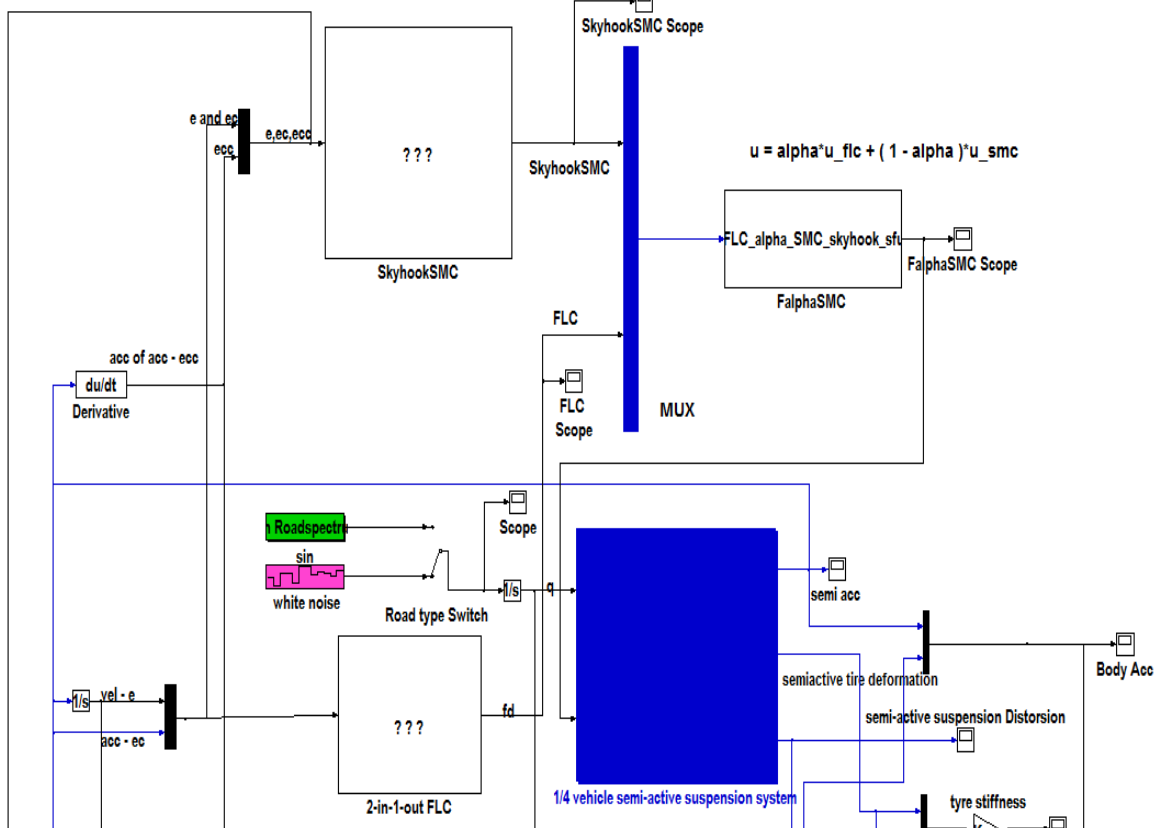


Fig 6(b): Simulink Model of Fuzzy control along with Skyhook controlled Suspension system

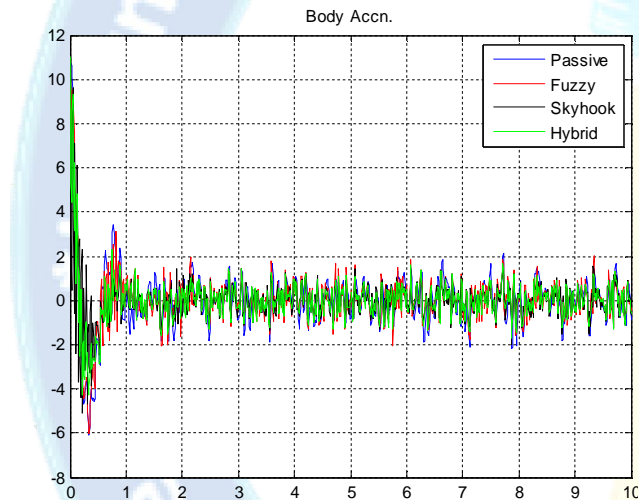
In this paper we have considered following added fuzzy rules to enhance the accuracy of the system performance:

**Table 2: Fuzzy Rules**

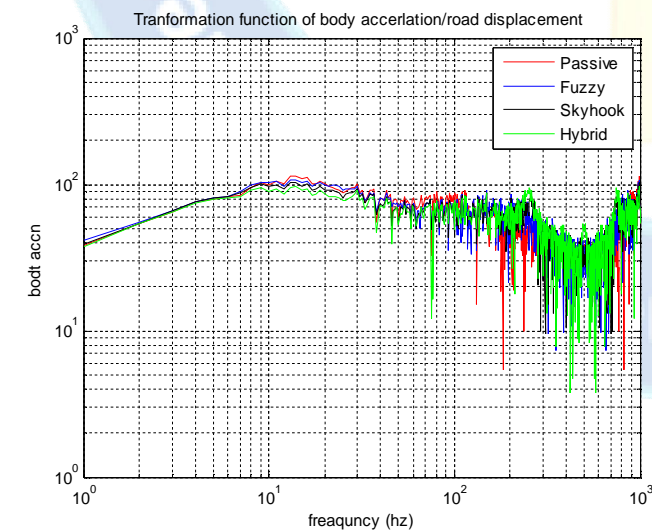
U		NL	EC	Z	PS	PL
	NL	Z	Z	Z	Z	Z
E	NS	Z	PS	Z	NS	Z
	Z	PM	PS	Z	Z	NM
	PS	PM	PM	NS	NM	NM
	PL	PS	PS	NS	NL	NL

**4. Result and Discussion:**

All the plots of system response are collectively shown in fig 7. The results are also demonstrated as the range of different responses during initial stages and the steady state stage. Fig 8 is obtained by taking the Fourier transform of the body acceleration/ road displacement vs the frequency in hertz. Since human body is mainly sensitive to accelerations in the frequency range of max 10 hertz hence fig 9 is again shown in the enlarged view to observe the reduction in body acceleration by all the four method. In this fig we can clearly see that our proposed hybrid controller gives minimum resonance peak of the acceleration.

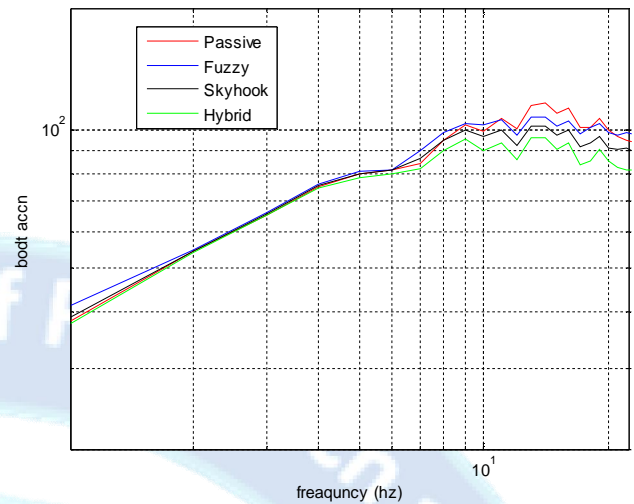


**Fig 7: Combined Plot of Body Accn.**



**Fig 8: Transformation Function of Body Acceleration.**

Transformation function of body acceleration/road displacement



**Fig 9: Transformation Function of Body Acceleration (Enlarge View).**

**5. Conclusion:**

In this work additional 5x5 fuzzy rule are considered to enhance the standard fuzzy inference system based suspension control mechanism. It has been observed that by using this novel fuzzy logic controlled system in hybridization with classical sliding mode non linear control theory body aberration occurred due to road vibrations are significantly reduced. The power spectrum of the body acceleration in frequency domain is also generated. It also justifies that the resonant peak by adder fuzzy rule hybrid suspension control mechanism gets reduced that can improve the ride comfort.

**References:**

- [1] John Y. Hung, "Variable Structure Control: A Survey", IEEE TRANSACTIONS ON INDUSTRIAL ELECTRONICS, VOL. 40, NO. 1, FEBRUARY 1993.
- [2] J.J. Slotine et. al, "Tracking Control Of Non-Linear Systems Using Sliding Surfaces With Application To Robot Manipulators" December 1982 LIDS-P-1264.
- [3] Yanqing LIU et.al, "Semi-active vibration isolation system with variable stiffness and damping control",
- [4] Rajeswari Kothandaraman et. al., "PSO tuned Adaptive Neuro-fuzzy Controller for Vehicle Suspension Systems", journal of advances in information technology, vol. 3, no. 1, february 2012.
- [5] M. Kondalu et. al., "Vehicle Suspension System Control by using Adaptive Fuzzy Controller" International Journal of Engineering and Technology Volume 2 No. 3, March, 2012